

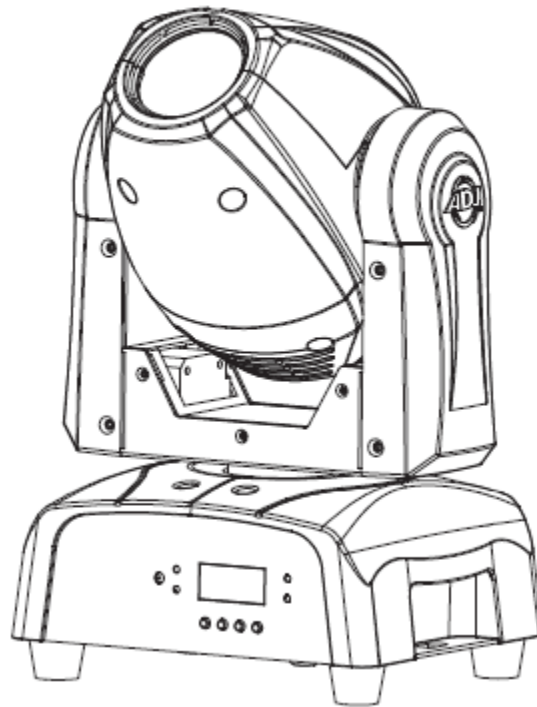

FOCUS SPOT ONE



User Instructions

A.D.J. Supply Europe B.V.
Junostraat 2
6468 EW Kerkrade
The Netherlands
www.americandj.eu

©2016 **ADJ Products, LLC** all rights reserved. Information, specifications, diagrams, images, and instructions herein are subject to change without notice. ADJ Products, LLC logo and identifying product names and numbers herein are trademarks of ADJ Products, LLC. Copyright protection claimed includes all forms and matters of copyrightable materials and information now allowed by statutory or judicial law or hereinafter granted. Product names used in this document may be trademarks or registered trademarks of their respective companies and are hereby acknowledged. All non-ADJ Products, LLC brands and product names are trademarks or registered trademarks of their respective companies.

ADJ Products, LLC and all affiliated companies hereby disclaim any and all liabilities for property, equipment, building, and electrical damages, injuries to any persons, and direct or indirect economic loss associated with the use or reliance of any information contained within this document, and/or as a result of the improper, unsafe, insufficient and negligent assembly, installation, rigging, and operation of this product.

Contents

GENERAL INFORMATION	4
GENERAL INSTRUCTIONS	4
FEATURES.....	4
HANDLING PRECAUTIONS.....	4
SAFETY PRECAUTIONS	4
MOUNTING	5
CAD DRAWING	6
BASE LAYOUT	7
DMX SET UP	8
15 CHANNEL MODE	10
17 CHANNEL MODE	12
SYSTEM MENU	15
HOME ADJUSTEMENT MENU	17
OPERATION	19
POWER CORD DAISY CHAIN.....	19
REMOTE OPERATION	20
CHANGING THE GOBO	20
REMOVING THE HEAD CASING	20
PHOTOMETRIC CHART	21
DIMMER CURVE CHART	22
FUSE REPLACEMENT	22
CLEANING.....	22
TROUBLE SHOOTING.....	23
SPECIFICATIONS	23
ROHS - A great Contribution to the Conservation of Environment	25
WEEE – Waste of Electrical and Electronic Equipment	26
NOTES	27

GENERAL INFORMATION

Unpacking: Thank you for purchasing the Focus Spot One by ADJ Products, LLC. Every Focus Spot One has been thoroughly tested and has been shipped in perfect operating condition. Carefully check the shipping carton for damage that may have occurred during shipping. If the carton appears to be damaged, carefully inspect your fixture for any damage and be sure all equipment necessary to operate the unit has arrived intact. In the event damage has been found or parts are missing, please contact our toll free customer support number for further instructions. Please do not return this unit to your dealer without contacting customer support first.

Introduction: The Focus Spot One is a DMX intelligent, moving head, mini LED wash. The Focus Spot One can operate as a stand alone fixture or in a Master/Slave set up. The Focus Spot One has three operating modes; a sound active, show mode, DMX controlled. This fixture is suitable for theaters, studios, retail stores, and other similar locations. *For best results use fog or special effects smoke to enhance the beams projections.*

Customer Support: If you encounter any problems, please contact your trusted American Audio shop. We also offer the possibility, to contact us directly: You can contact us via our website www.americandj.eu or via email: support@americandj.eu

Warning! To prevent or reduce the risk of electrical shock or fire, do not expose this unit to rain or moisture.

Warning! *This may cause severe eye damage. Avoid looking directly into the light source at all times!*

GENERAL INSTRUCTIONS

To optimize the performance of this product, please read these operating instructions carefully to familiarize yourself with the basic operations of this unit. These instructions contain important safety information regarding the use and maintenance of this unit. Please keep this manual with the unit, for future reference.

FEATURES

- DMX-512 Protocol Compatible (2 DMX Channel Modes: 15 Channels & 17 Channels)
- 3 Operating Modes - Sound Active, Show Mode, & DMX Control
- 5 Dimmer Curves (Standard, Stage, TV, Architectural, & Theatre)
- Internal Microphone
- Digital Display for Address and Function Setting
- 4 Preprogrammed Shows
- UC IR and Airstream IR Compatible (Not Included)

HANDLING PRECAUTIONS

Caution! There are no user serviceable parts inside this unit. Do not attempt any repairs yourself, doing so will void your manufactures warranty. In the unlikely event your unit may require service please contact ADJ Products, LLC.

During operation the housing may become extremely hot. Avoid touching the unit with bare hands while in use. ADJ Products, LLC will not accept any liability for any resulting damages caused by the non-observance of this manual or any unauthorized modification to this unit.

SAFETY PRECAUTIONS

For Your Own Personal Safety, Please Read and Understand This Manual Completely Before You Attempt To Install Or Operate This Unit!

- To reduce the risk of electrical shock or fire, do not expose this unit rain or moisture
- Do not spill water or other liquids into or on to your unit.
- Be sure that the local power outlet match that of the required voltage for your unit.
- Do not attempt to operate this unit if the power cord has been frayed or broken.
- Do not attempt to remove or break off the ground prong from the electrical cord. This prong is used to reduce the risk of electrical shock and fire in case of an internal short.
- Disconnect from main power before making any type of connection.
- Do not remove the cover under any conditions. There are no user serviceable parts inside.
- Never operate this unit when it's cover is removed.

SAFETY PRECAUTIONS (continued)

- Always be sure to mount this unit in an area that will allow proper ventilation. Allow about 6" (15cm) between this device and a wall.
- Do not attempt to operate this unit, if it becomes damaged.
- This unit is intended for indoor use only, use of this product outdoors voids all warranties.
- Always mount this unit in safe and stable matter.
- Power-supply cords should be routed so that they are not likely to be walked on or pinched by items placed upon or against them, paying particular attention to cords at plugs, convenience receptacles, and the point where they exit from the appliance.
- Cleaning -The fixture should be cleaned only as recommended by the manufacturer. See [page 23](#) for cleaning details.
- Heat -This fixture should be situated away from heat sources such as radiators, heat registers, stoves, or other appliances (including amplifiers) that produce heat.
- The fixture should be serviced by qualified service personnel when:
 - A. Objects have fallen, or liquid has been spilled into the appliance.
 - B. The appliance has been exposed to rain or water.
 - C. The appliance does not appear to operate normally or exhibits a marked change in performance.

MOUNTING

When installing the unit, the trussing or area of installation must be able to hold 10 times the weight without any deformation. When installing the unit must be secured with a secondary safety attachment, e.g. and appropriate safety cable. Never stand directly below the unit when mounting, removing, or servicing the unit.

Overhead mounting requires extensive experience, including calculating working load limits, installation material being used, and perodic safety inspection of all installation material and unit. If you lack these qualifications, do not attempt the installation yourself.

The installaiton should be checked by a skilled person once a year.

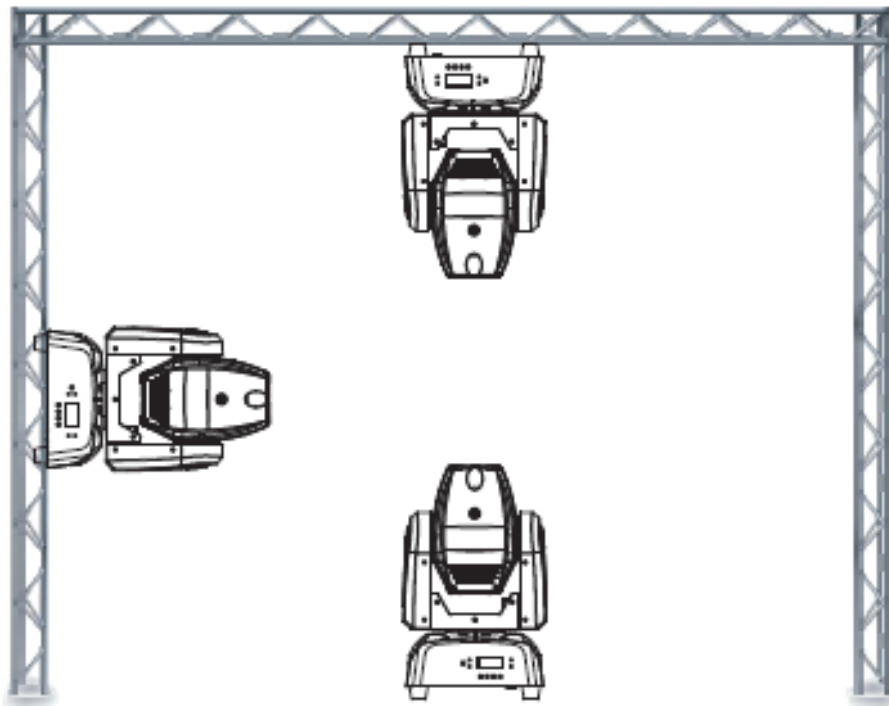

MOUNTING (continued)

The Focus Spot One is fully operational in three different positions, hanging upside-down from a ceiling or trussing, mounted sideways on trussing, or set on a flat level surface. Be sure this fixture is kept at least 0.5m away from any flammable materials (decoration etc.). Always use and install the supplied safety cable as a safety measure to prevent accidental damage and/or injury in the event the clamp fails ([see next page](#)).

NOTICE: The suitable environmental temperature for this lighting fixture is between -25° C to 45° C. Do not place this lighting fixture in an environment where the temperatures are under or above the temperatures stated above. This will allow the fixture to run at its best and help prolong the fixture life.

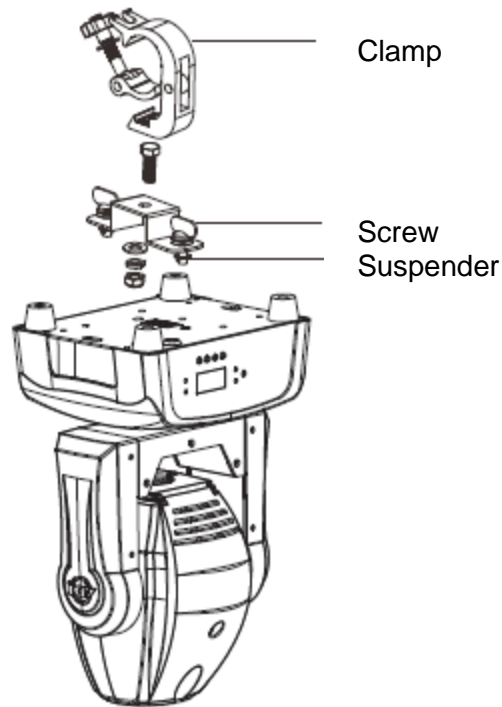

Screw one clamp via a M12 screw and nut to the included bracket. Attach the bracket using the omega locks to the bottom of the Focus Spot One. Attach and pull the safety-cable through one of the safety holes located on the bottom base and over the trussing system or a safe fixation spot. Insert the end in the carabine and tighten the safety screw.

CAD DRAWING

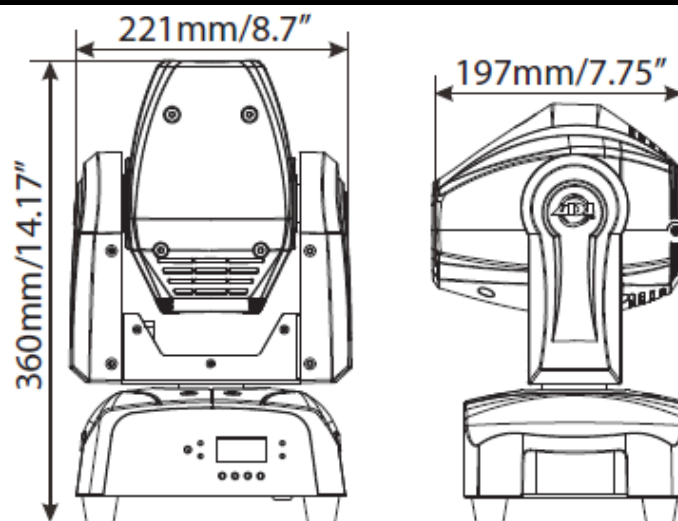

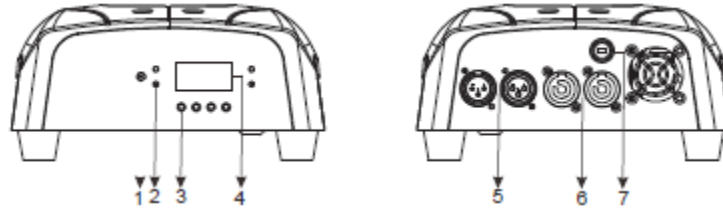

1. IRReceiver: To receive the IR signal;

2.LED:

DMX	On	DMX input present
MASTER	On	Master Mode
SLAVE	ON	Slave Mode
SOUND	Flashing	Sound activation

3.Button:

MENU	To select the programming functions
▲ UP	To go forward in the selected functions
▼ DOWN	To go backward in the selected functions
ENTER	To confirm the selected functions

4. Display:To show the various menus and the selected function;

5. DMX In/Out: 3-pin XLR connectors for DMX 512 operation;

6. Power In/out: Connectors for power input/output;

7.Fuse(T6.3Amp): Protects the unit from over-voltage or short circuit.

DMX SET UP

Power Supply: The ADJ Focus Spot One contains a automatic voltage switch, which will auto sense the voltage when it is plugged into the power source. With this switch there is no need to worry about the correct power voltage, this unit can be plugged in anywhere.

DMX-512: DMX is short for Digital Multiplex. This is a universal protocol used by most lighting and controller manufactures as a form of communication between intelligent fixtures and controllers. A DMX controller sends DMX data instructions from the controller to the fixture. DMX data is sent as serial data that travels from fixture to fixture via the DATA “IN” and DATA “OUT” XLR terminals located on all DMX fixtures (most controllers only have a DATA “OUT” terminal).

DMX Linking: DMX is a language allowing all makes and models of different manufactures to be linked together and operate from a single controller, as long as all fixtures and the controller are DMX compliant. *To ensure proper DMX data transmission, when using several DMX fixtures try to use the shortest cable path possible. The order in which fixtures are connected in a DMX line does not influence the DMX addressing. For example; a fixture assigned a DMX address of 1 may be placed anywhere in a DMX line, at the beginning, at the end, or anywhere in the middle. Therefore, the first fixture controlled by the controller could be the last fixture in the chain. When a fixture is assigned a DMX address of 1, the DMX controller knows to send DATA assigned to address 1 to that unit, no matter where it is located in the DMX chain.*

Data Cable (DMX Cable) Requirements (For DMX and Master/Slave Operation): The Focus Spot One can be controlled via DMX-512 protocol. The Focus Spot One has 2 DMX channel modes; 15 channel mode & 17 channel mode. The DMX address is set electronically using the controls on the front panel of the unit. Your unit and your DMX controller require a approved DMX-512 110 Ohm Data cable for data input and data output (Figure 1). We recommend Accu-Cable DMX cables. If you are making your own cables, be sure to use standard 110-120 Ohm shielded cable (This cable may be purchased at almost all professional sound and lighting stores). Your cables should be made with a male and female XLR connector on either end of the cable. Also remember that DMX cable must be daisy chained and cannot be split.



Figure 1

NOTICE: Be sure to follow figures two and three when making your own cables. Do not use the ground lug on the XLR connector. Do not connect the cable’s shield conductor to the ground lug or allow the shield conductor to come in contact with the XLR’s outer casing. Grounding the shield could cause a short circuit and erratic behavior.

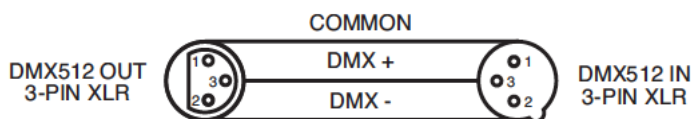

Figure 2

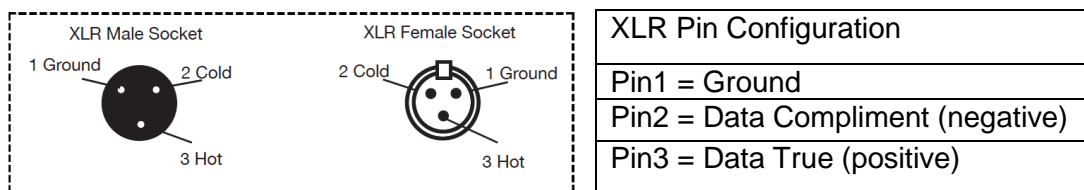
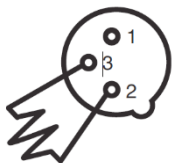

Figure 3

DMX SET UP(continued)

Special Note: Line Termination. When longer runs of cable are used, you may need to use a terminator on the last unit to avoid erratic behavior. A terminator is a 110-120 ohm 1/4 watt resistor which is connected between pins 2 and 3 of a male XLR connector (DATA + and DATA -). This unit is inserted in the female XLR connector of the last unit in your daisy chain to terminate the line. Using a cable terminator (ADJ part number Z-DMX/T) will decrease the possibilities of erratic behavior.



Termination reduces signal errors and avoids signal transmission problems and interference. It is always advisable to connect a DMX terminal, (Resistance 120 Ohm 1/4 W) between PIN 2 (DMX-) and PIN 3 (DMX +) of the last fixture.

Figure 4

5-Pin XLR DMX Connectors Some manufactures use 5-pin DMX- 512 data cables for DATA transmission in place of 3-pin. 5-pin DMX fixtures may be implemented in a 3-pin DMX line. When inserting standard 5-pin data cables in to a 3-pin line a cable adaptor must be used, these adaptors are readily available at most electric stores. The chart below details a proper cable conversion.

3-Pin XLR to 5-Pin XLR Conversion		
Conductor	3-pin XLR Female (Out)	5-pin XLR Male (In)
Ground/Shield	Pin 1	Pin 1
Data compliment (- signal)	Pin 2	Pin 2
Data True (+ signal)	Pin 3	Pin 3
Not used		Pin 4 - Do Not Use
Not used		Pin 5 - Do Not Use

15 CHANNEL MODE

Channel	Value	Function
1	0 - 255	PAN MOVEMENT 0° - 540°
2	0 - 255	TILT MOVEMENT 0° - 240°
3	0 - 14 15 - 29 30 - 44 45 - 59 60 - 74 75 - 89 90 - 104 105 - 119 120 - 127 128 - 189 190 - 193 194 - 255	COLOR WHITE RED BLUE GREEN YELLOW PINK NAVY BLUE NAVY GREEN NAVY YELLOW CLOCKWISE ROTATION FAST - SLOW STOP COUNTER-CLOCKWISE ROTATION SLOW - FAST
4	0 - 9 10 - 19 20 - 29 30 - 39 40 - 49 50 - 59 60 - 63 64 - 73 74 - 82 83 - 91 92 - 100 101 - 109 110 - 118 119 - 127 128 - 189 190 - 193 194 - 255	GOBOS OPEN GOBO 1 GOBO 2 GOBO 3 GOBO 4 GOBO 5 GOBO 6 OPEN SHAKE GOBO 1 SHAKE GOBO 2 SHAKE GOBO 3 SHAKE GOBO 4 SHAKE GOBO 5 SHAKE GOBO 6 SHAKE CLOCKWISE ROTATION FAST - SLOW STOP COUNTER-CLOCKWISE ROTATION SLOW - FAST
5	0 - 127 128 - 189 190 - 193 194 - 255	GOBO ROTATION INDEXING CLOCKWISE ROTATION FAST - SLOW STOP COUNTER-CLOCKWISE ROTATION SLOW - FAST
6	0 - 255	FOCUS 0% - 100%
7	0 - 7 8 - 15 16 - 131 132 - 139 140 - 181 182 - 189 190 - 231 232 - 239 240 - 247 248 - 255	STROBE/SHUTTER OFF OPEN STROBING SLOW - FAST OPEN SLOW OPEN - FAST CLOSE OPEN FAST OPEN - SLOW CLOSE OPEN RANDOM STROBE SLOW - FAST OPEN

15 CHANNEL MODE (continued)

Channel	Value	Function
8	0 - 255	MASTER DIMMER 0% - 100%
9	0 - 7 8 - 15 16 - 131 132 - 139 140 - 181 182 - 189 190 - 231 232 - 239 240 - 247 248 - 255	UV STROBING OFF OPEN STROBING SLOW - FAST OPEN SLOW OPEN - FAST CLOSE OPEN FAST OPEN - SLOW CLOSE OPEN RANDOM STROBE SLOW - FAST OPEN
10	0 - 255	UV MASTER DIMMER 0% - 100%
11	0 1 - 21 22 - 41 42 - 61 62 - 81 82 - 255	SHOW OFF SHOW 1 SHOW 2 SHOW 3 SHOW 4 SHOW 0 (RANDOM SHOW)
12	0 - 255	SHOW SPEED FAST - SLOW
13	0 - 20 21 - 40 41 - 60 61 - 80 81 - 100 101 - 255	DIMMER MODES STANDARD STAGE TV ARCHITECTURAL THEATRE DEFAULT TO UNIT
14	0 - 255	PAN/TILT SPEED FAST - SLOW
15	0 - 69 70 - 79 80 - 89 90 - 99 100 - 109 110 - 119 120 - 129 130 - 139 140 - 199 200 - 209 210 - 249 250 - 255	FUNCTION NOTHING BLACKOUT WITH PAN/TILT NOTHING BLACKOUT WITH COLOR CHANGE NOTHING BLACKOUT WITH GOBO CHANGE NOTHING ENABLE SPLIT COLORS NOTHING RESET ALL NOTHING SOUND ACTIVE



17 CHANNEL MODE

Channel	Value	Function
1	0 - 255	PAN MOVEMENT 0° - 540°
2	0 - 255	PAN FINE 0% - 100%
3	0 - 255	TILT MOVEMENT 0° - 240°
4	0 - 255	TILT FINE 0% - 100%
5	0 - 14 15 - 29 30 - 44 45 - 59 60 - 74 75 - 89 90 - 104 105 - 119 120 - 127 128 - 189 190 - 193 194 - 255	COLOR WHITE RED BLUE GREEN YELLOW PINK NAVY BLUE NAVY GREEN NAVY YELLOW CLOCKWISE ROTATION FAST - SLOW STOP COUNTER-CLOCKWISE ROTATION SLOW - FAST
6	0 - 9 10 - 19 20 - 29 30 - 39 40 - 49 50 - 59 60 - 63 64 - 73 74 - 82 83 - 91 92 - 100 101 - 109 110 - 118 119 - 127 128 - 189 190 - 193 194 - 255	GOBOS OPEN GOBO 1 GOBO 2 GOBO 3 GOBO 4 GOBO 5 GOBO 6 OPEN SHAKE GOBO 1 SHAKE GOBO 2 SHAKE GOBO 3 SHAKE GOBO 4 SHAKE GOBO 5 SHAKE GOBO 6 SHAKE CLOCKWISE ROTATION FAST - SLOW STOP COUNTER-CLOCKWISE ROTATION SLOW - FAST

17 CHANNEL MODE (continued)

Channel	Value	Function
7	0 - 127 128 - 189 190 - 193 194 - 255	GOBO ROTATION INDEXING CLOCKWISE ROTATION FAST - SLOW STOP COUNTER-CLOCKWISE ROTATION SLOW - FAST
8	0 - 255	FOCUS 0% - 100%
9	0 - 7 8 - 15 16 - 131 132 - 139 140 - 181 182 - 189 190 - 231 232 - 239 240 - 247 248 - 255	STROBE/SHUTTER OFF OPEN STROBING SLOW - FAST OPEN SLOW OPEN - FAST CLOSE OPEN FAST OPEN - SLOW CLOSE OPEN RANDOM STROBE SLOW - FAST OPEN
10	0 - 255	MASTER DIMMER 0% - 100%
11	0 - 7 8 - 15 16 - 131 132 - 139 140 - 181 182 - 189 190 - 231 232 - 239 240 - 247 248 - 255	UV STROBING OFF OPEN STROBING SLOW - FAST OPEN SLOW OPEN - FAST CLOSE OPEN FAST OPEN - SLOW CLOSE OPEN RANDOM STROBE SLOW - FAST OPEN
12	0 - 255	UV MASTER DIMMER 0% - 100%
13	0 1 - 21 22 - 41 42 - 61 62 - 81 82 - 255	SHOW OFF SHOW 1 SHOW 2 SHOW 3 SHOW 4 SHOW 0 (RANDOM SHOW)
14	0 - 255	SHOW SPEED FAST - SLOW
15	0 - 20 21 - 40 41 - 60 61 - 80 81 - 100 101 - 255	DIMMER MODES STANDARD STAGE TV ARCHITECTURAL THEATRE DEFAULT TO UNIT
16	0 - 255	PAN/TILT SPEED FAST - SLOW

17 CHANNEL MODE (continued)

Channel	Value	Function
17	0 - 69	FUNCTION NOTHING
	70 - 79	BLACKOUT WITH PAN/TILT
	80 - 89	FUNCTION NOTHING
	90 - 99	BLACKOUT WITH COLOR CHANGE
	100 - 109	FUNCTION NOTHING
	110 - 119	BLACKOUT WITH GOBO CHANGE
	120 - 129	FUNCTION NOTHING
	130 - 139	ENABLE SPLIT COLORS
	140 - 199	FUNCTION NOTHING
	200 - 209	RESET ALL
210 - 249	FUNCTION NOTHING	
250 - 255	SOUND ACTIVE	



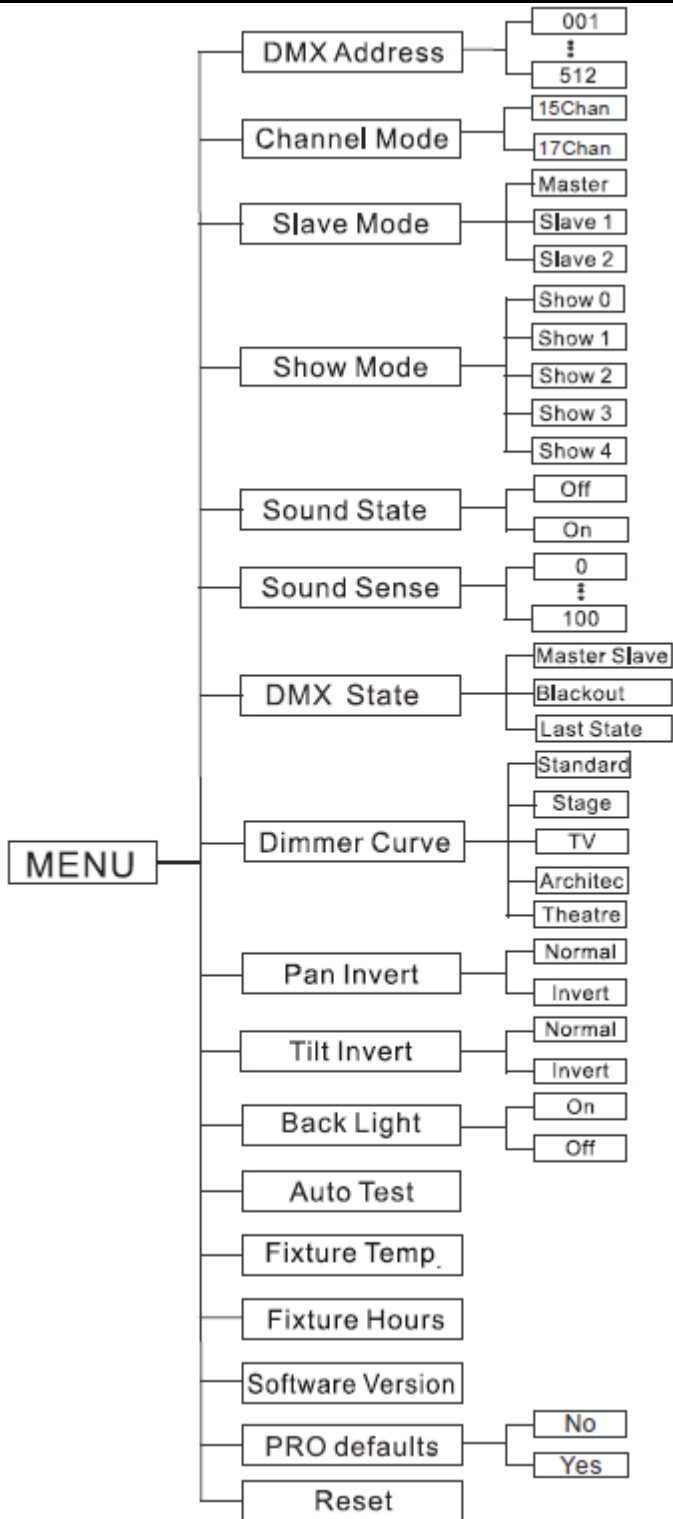

SYSTEM MENU (continued)

System Menu: System Menu: When making adjustments press ENTER to confirm your setup then press and hold the MENU button for at least 3 seconds. To exit without making any adjustments press the MENU button. The display will lock after 30 seconds, press the MENU button for 3 seconds to unlock

DMX Address - Set the DMX Address –

1. Press the MENU button until “DMX Address” is displayed, press ENTER.
2. “X” will now be displayed, “X” represents the displayed address. Press the UP or DOWN buttons to find your desired address.
3. Press ENTER to confirm, and then press and hold the MENU button for at least three seconds to assign.

Channel Mode - This will let you select your desired DMX Channel mode.

1. Press the MENU button until “Channel Mode” is displayed, press ENTER.
2. “X Chan” will now be displayed, “X” represents the displayed DMX channel mode. Press the UP or DOWN buttons to find your desired Channel mode.
3. Press ENTER to confirm.

Slave Mode - This will let you set unit as a master or slave in a master/slave configuration.

1. Press the MENU button until “Slave Mode” is displayed, press ENTER. Either “Master”, “Slave 1” or “Slave 2” will be displayed.
2. Press the UP or DOWN buttons until your desired setting is displayed, then press ENTER to confirm.

Note In a Master/Slave configuration you can make one fixture the Master and then set the next fixture to “Slave 2”, the fixtures will now have contrast movement to each other.

Show Mode - Show modes 1 - 4 (Factory Shows).

1. Press the MENU button until “Show Mode” is displayed, press ENTER.
2. “Show X” will now be displayed, “X” representing a number between 0-4. Shows 1-4 are factory programs, while show “0” is random mode. Use the UP or DOWN buttons to find your desired show.

Sound State - In this mode the unit will run in sound active mode.

1. Press the MENU button until “Sound State” is displayed, press ENTER.
2. Either “On” or “Off” will now be displayed. Use the UP or DOWN buttons to toggle between “On” and “Off”.
3. Press ENTER to confirm your selection, then press and hold the MENU button to activate.

Sound Sense - In this mode you can adjust the sound sensitivity of the sound active mode.

1. Press the MENU button until “Sound Sense” is displayed, press ENTER.
2. Press the UP or DOWN buttons to adjust the sensitivity level. The sensitivity level can be adjusted between 0 (the lowest) and 100 (most sensitive).
3. Press ENTER to set your desired level.

DMX Last State - This mode can be used as a precaution mode, that in case the DMX signal is lost, the operating mode chosen in the setup is the running mode the fixture will go into when the DMX signal is lost. You can also set this as the operating mode you would like the unit to return to when power is applied.

1. Press the MENU button until “Last State” is displayed, press ENTER.
2. Either “Master Slave”, “Blackout”, or “Last State” will be displayed. Choose an operating mode you would like the unit to start up in when power is applied or the DMX signal is lost.
 - Master Slave - If the DMX signal is lost or power is applied, the unit will automatically go into Master Slave mode.
 - Blackout - If the DMX signal is lost or power is applied, the unit will automatically go into stand by mode.
 - Last State - If the DMX signal is lost the fixture will stay in the last DMX set up. If power is applied and this mode is set, the unit will automatically go into the last DMX set up.
3. Press ENTER to confirm your desired set up.

SYSTEM MENU (continued)

Dimmer Curve - In this mode you can select the dimmer curve.

1. Press the MENU button until “Dimmer Curve” is displayed, press ENTER.
2. The current dimmer curve setting will be displayed.
3. Press the UP or DOWN buttons to find your desired dimmer curve and press ENTER to confirm. See the Dimmer Curve Chart on [page 22](#) for the different settings.

Pan Invert - Pan Inversion

1. Press the MENU button until “Pan Invert” is displayed, press ENTER. Either “Yes” or “No” will be displayed.
2. To activate the Pan inversion press the UP or DOWN buttons until “Yes” is displayed, press ENTER to confirm. To deactivate Pan inversion, select “No” and press Enter.

Tilt Invert - Tilt Inversion

1. Press the MENU button until “Tilt Invert” is displayed, press ENTER. Either “Yes” or “No” will be displayed.
2. To activate the Tilt inversion press the UP or DOWN buttons until “Yes” is displayed, press ENTER to confirm. To deactivate Tilt inversion, select “No” and press Enter.

Back Light - With this function you can make the backlight automatically turn off after one minute.

1. Press the MENU button until “Back Light” is displayed, press ENTER.
2. Either “On” or “Off” will now be displayed. Press the UP or DOWN buttons to select “On” to keep the backlight on at all times, or “Off” to allow the backlight to turn off after 1 minute. Press any button to turn the backlight on again.

Auto Test - This function will run a self test program.

1. Press the MENU button until “Auto Test” is displayed, press ENTER.
2. The fixture will now run a self test. Press the MENU button to exit.

Fixture Temp. - With this function you can display the running temperature of the unit.

1. Press the MENU button until “Fixture Temp.” is displayed, press ENTER.
2. The current running temperature of the fixture will now be displayed. Press MENU to exit.

Fixture Hours - With this function you can display the running time of the unit.

1. Press the MENU button until “Fixture Hours” is displayed, press ENTER.
2. The running time of the fixture will now be displayed. Press MENU to exit.

Software Version - This will display the firmware/software version

1. Press the MENU button until “Software Version” is displayed. Press the ENTER button and the software version will be displayed.
2. Press the MENU button to leave this function.

PRO Defaults - This function will restore all factory settings.

1. Press the MENU button until “PRO defaults” is displayed, press ENTER. Either “Yes” or “No” will be displayed.
2. To restore factory settings press the UP or DOWN buttons until “Yes” is displayed, press ENTER to confirm. If you do not wish restore the settings, select “No” and press Enter.

Reset - Use this function to reset the motors.

1. Press the MENU button until “Reset” is displayed, press ENTER. Press the MENU button to leave this function.
2. The fixture will now reset.

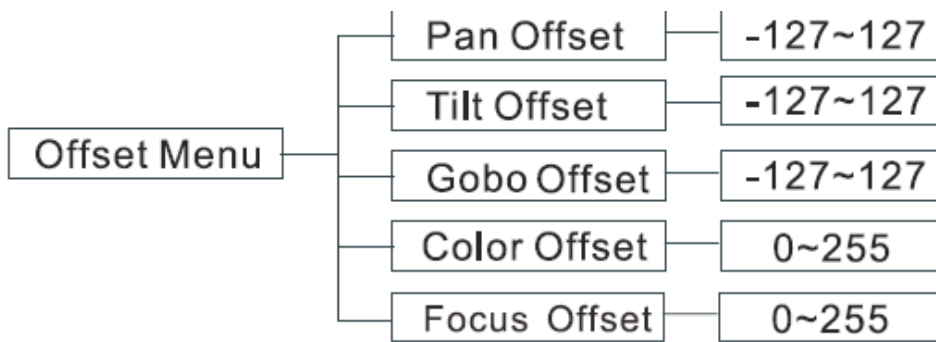

To enter the Offset Menu, press the MENU button to unlock the display, then press the ENTER button for at least 5 seconds. In this submenu you are able to adjust the home position of the pan, tilt, gobo wheel, color wheel, and focus. To exit this menu press and hold the MENU button.

Pan Offset - Adjustment of the pan home position.

1. Press the ENTER button for at least 5 seconds, then press the UP or DOWN buttons so that “**Pan Offset**” is displayed, press ENTER.
2. Use the UP and DOWN buttons to make your adjustments, and then press ENTER to confirm. Press the MENU button for one second to exit.

Tilt Offset - Adjustment of the tilt home position.

1. Press the ENTER button for at least 5 seconds, then press the UP or DOWN buttons so that “**Tilt Offset**” is displayed, press ENTER.
2. Use the UP and DOWN buttons to make your adjustments, and then press ENTER to confirm. Press the MENU button for one second to exit.

Gobo Offset - Setting adjustment for the gobo wheel.

1. Press the ENTER button for at least 5 seconds, then press the UP or DOWN buttons so that “**Gobo Offset**” is displayed, press ENTER.
2. Use the UP and DOWN buttons to make your adjustments, and then press ENTER to confirm. Press the MENU button for one second to exit.

Color Offset - Setting adjustment for the color wheel.

1. Press the ENTER button for at least 5 seconds, then press the UP or DOWN buttons so that “**Color**” is displayed, press ENTER.
2. Use the UP and DOWN buttons to make your adjustments, and then press ENTER to confirm. Press the MENU button for one second to exit.

Focus Offset - Setting adjustment for the focus.

1. Press the ENTER button for at least 3 seconds, then press the UP or DOWN buttons so that “**Focus Offset**” is displayed, press ENTER.
2. Use the UP and DOWN buttons to make your adjustments, and then press ENTER to confirm. Press the MENU button for one second to exit.

OPERATION

Universal DMX Control: This function allows you to use a universal DMX-512 controller to control the pan, tilt, gobos, colors, focusing, dimmer and strobe. A DMX controller allows you to create unique programs tailored to your individual needs.

1. The Focus Spot One has 2 DMX channel modes; 15 channel mode and 17 channel mode. See [pages 10-14](#) detailed description of the DMX values and traits.
2. To control your fixture in DMX mode, follow the set-up procedures on [pages 8-9](#) as well as the set-up specifications that are included with your DMX controller.
3. Use the controller's faders to control the various DMX fixture traits.
4. This will allow you to create your own programs.
5. Follow the instructions on [page 16](#) to select your desired DMX channel mode and to set the DMX address.
6. For longer cable runs (more than a 100 feet) use a terminator on the last fixture.
7. For help operating in DMX mode consult the manual included with your DMX controller.

Sound Active Mode: This mode allows either single unit or several units linked together, to run to the beat of the music.

1. Press the MENU button until "**Sound State**" is displayed, and press ENTER. Press the UP or DOWN buttons so that "**ON**" is displayed and press ENTER.
2. Press the MENU button until "**Sound Sense**" is displayed, and press ENTER. Use the UP and DOWN buttons to adjust the sound sensitivity. Press ENTER when you have found your desired sensitivity level.

Show Mode: This mode allows either a single unit or several units linked together, to run one of four shows that you choose.

1. Press the MENU button until "**Show Mode**" is displayed, and press ENTER.
2. Press the UP or DOWN buttons to find your desired show, and press ENTER.

Master-Slave Operation This function will allow you to link up to 16 units together and operate without a controller. The units will be sound activated. In Master-Slave operation one unit will act as the controlling unit and the others will react to the controlling units programs. Any unit can act as a Master or as a Slave.

1. Using approved DMX data cables, daisy chain your units together via the XLR connector on the rear of the units. Remember the Male XLR connector is the input and the Female XLR connector is the output. The first unit in the chain (master) will use the female XLR connector only - The last unit in the chain will use the male XLR connector only. For longer cable runs we suggest a terminator at the last fixture.
2. On the Master unit press the MENU button until "**Slave Mode**" is displayed, and press ENTER. Use the UP and DOWN buttons to scroll to the "**Master**" setting and press ENTER.
3. After setting the Master unit to the master setting find and set your desired operating mode.
4. On the slave units press the MENU button until "**Slave Mode**" is displayed, and press ENTER. Choose either "**Slave 1**" or "**Slave 2**" and press ENTER.
5. The slave units will now follow the Master unit.

POWER CORD DAISY CHAIN

With this feature you can connect the fixtures to one another using the PowerCon input and output sockets. The quantity that can be connected is 19 fixtures maximum @ 120V and 35 fixtures maximum @ 230V. After you have reached the maximum amount of fixtures you will need to use a new power outlet. They must be the same fixtures. DO NOT mix fixtures.

REMOTE OPERATION

The **UC IR** (sold separately) infrared remote gives you control of various functions (See below). To control the fixture you must aim the remote at the front of the fixture and be no more than 30 feet away.

The **Airstream IR (sold separately)** remote transmitter plugs into the headphone jack of your iOS phone or tablet. To control your IR fixture you must raise the volume to the maximum on your iOS phone or tablet and aim the transmitter at the fixture sensor and be no more than 15 feet away. After you have purchased the Airstream IR transmitters, the app is a free download from the app store for your iOS phone or tablet. The app comes with 3 pages of control depending on the fixture you are using. Please see below for IR functions. This unit works with App page 1.

STAND BY - Pressing this button will blackout the fixture.

FULL ON - Hold this button down to fully light up the unit. When you let the button go, the unit will return to its previous state.

FADE/GOBO - Press this button once to access gobo wheel. Use the number buttons to find your desired gobo.

“DIMMER +” and “DIMMER -” - Use these buttons to adjust the output intensity in Color mode.

STROBE - This button will activate the strobe effect. Press and hold this button to activate strobing and release the button to stop strobing.

COLOR - Press this button to access the color wheel. Use the number buttons to select your desired color. Adjust the output intensity using the “DIMMER +” and “DIMMER -” buttons.

1-9 - In color mode and gobo mode, these buttons will allow you to select a desired color or gobo. In show mode buttons 1-4 will let you select your desired show.

SOUND ON & OFF - These buttons activate and deactivate the sound active mode.

SHOW - This activates the show mode. Use buttons 1-4 to select your desired show.

CHANGING THE GOBO

The gobo's in this unit are interchangeable. Please be very careful when replacing the gobo.

Caution! *Never open the unit when in use. Always disconnect the main power before attempting to change the gobos.*

1. To change a gobo, rotate the moving head so that the UV lens is located on top. Unscrew the single middle screw. See instruction number 1 **on the next page**.
2. Once you loosen the single screw you are able to swing the head back. See instruction number 2 on the **next page**. You will now be able to access the gobo wheel. Turn the wheel with your hand until you come across the gobo you would like to change.
3. To remove the gobo holder gently pull the gobo holder towards the front of the unit and slide it up and out.
4. Gently and carefully remove the retainer ring. After the retainer ring is removed, carefully remove the gobo.
5. Change the gobo and replace the retainer ring. Carefully slide the gobo holder back into the housing slot.
6. Reassemble the unit.

REMOVING THE HEAD CASING

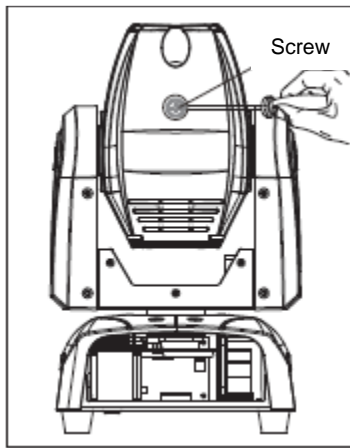

1. Unscrew the single screw

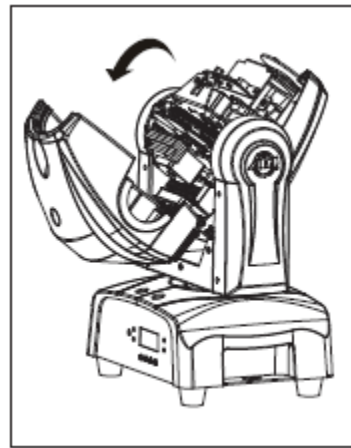

2. Flip the top cover back

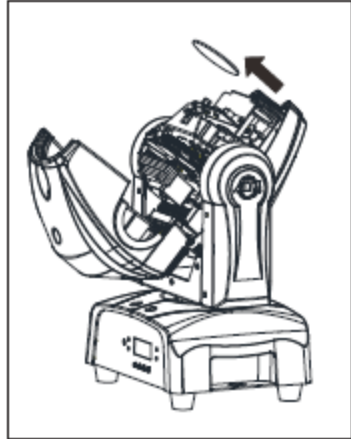

3. Remove the lens

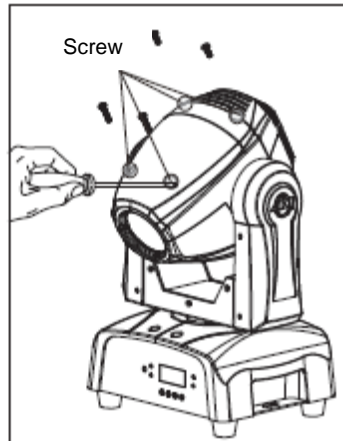

4. Unscrew the 4 screws located on the other side

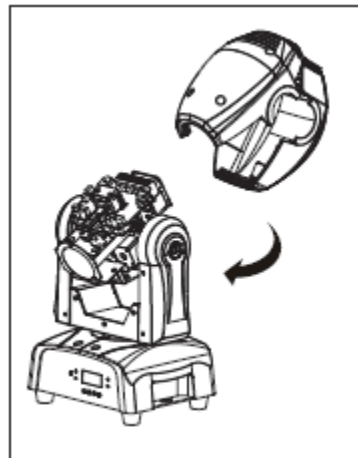

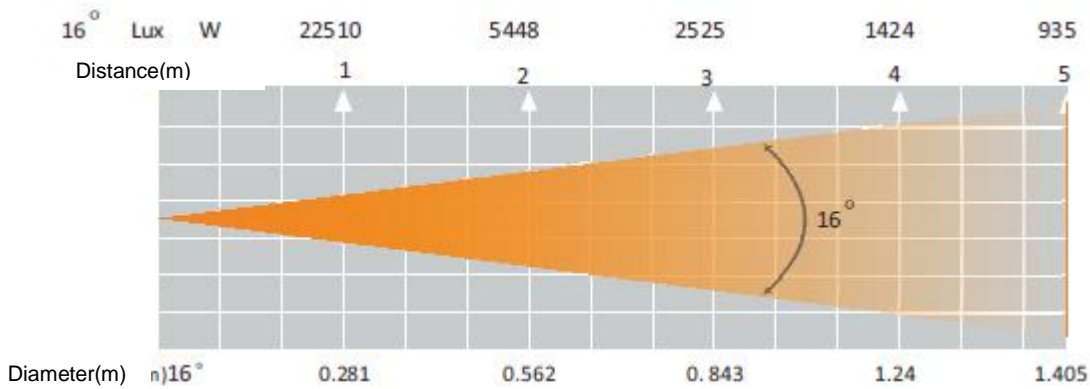

DIMMER CURVE CHART

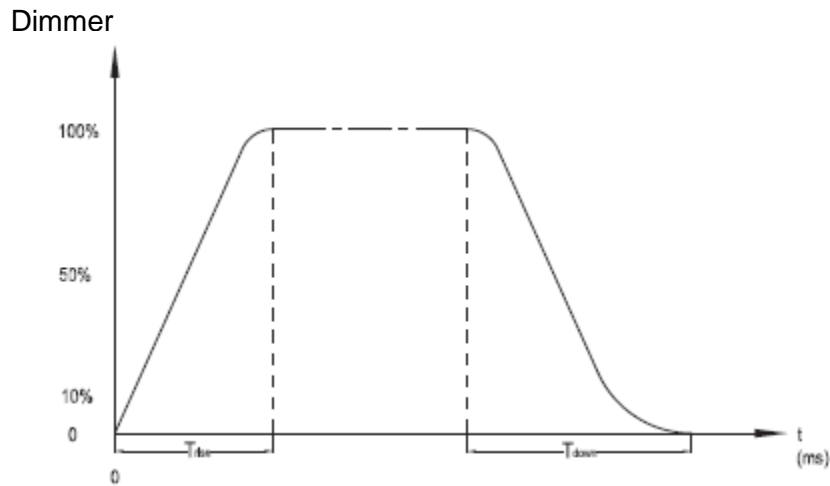

Ramp Effect	0 $\xrightarrow{255}$ 255 os(FadeTime)		0 $\xrightarrow{255}$ 255 1S (FadeTime)	
	T rise (ms)	Tdown (ms)	T rise (ms)	Tdown (ms)
Standard	0	0	0	0
Stage	780	1100	1540	1660
TV	1180	1520	1860	1940
Architectural	1380	1730	2040	2120
Theatre	1580	1940	2230	2280

FUSE REPLACEMENT

Locate and remove the unit's PowerCon cord. Once the cord has been removed the fuse holder is located next to the power socket. Use a philips head screw driver unscrew the fuse holder. Remove the bad fuse and replace with a new one.

CLEANING

Due to fog residue, smoke, and dust cleaning the internal and external optical lenses and mirror should be carried out periodically to optimize light output. Cleaning frequency depends on the environment in which the fixture operates (I.e. smoke, fog residue, dust, dew). In heavy club use we recommend cleaning on a monthly basis. Periodic cleaning will ensure longevity, and crisp output.

1. Use normal glass cleaner and a soft cloth to wipe down the outside casing.
2. Use a brush to wipe down the cooling vents and fan grill.
3. Clean the external optics with glass cleaner and a soft cloth every 20 days.
- 4 Clean the internal optics with glass cleaner and a soft cloth every.
5. Always be sure to dry all parts completely before plugging the unit back in.

TROUBLE SHOOTING

Trouble Shooting: Listed below are a few common problems that you may encounter, with solutions.

No light output from the unit;

1. Be sure the external fuse has not blown. The fuse is located on the rear panel of the unit.
2. Be sure the fuse holder is completely and properly seated.

Unit does not respond to sound;

1. Low frequencies (bass) should cause the unit to react to sound. Tapping on the microphone, quiet or high pitched sounds may not activate the unit.

SPECIFICATIONS

Model:	Focus Spot One
Voltage:	100-240V, 50/60Hz
LED:	1 x 35W Cold White LED 1x3W UV LED
Power Consumption:	81W
Dimensions:	7.25"(L) x 8.75"(W) x 14.25"(H) 197mm x 221mm x 360mm
Weight:	12,5 Lbs. / 8,7 kgs.
Beam Angle:	16 Degrees
Gobo Size :	23.8mm (Outer) 19mm (Inner/Image) 0.2mm (Thickness)
Fuse:	2 Amp
Power Cord Daisy Chain:	19 Fixtures Max. (120V) 35 Fixtures Max. (230V)
Duty cycle:	None
DMX:	2 DMX Channel Modes: 15 Channel Mode & 17 Channel Mode
Sound Active:	Yes
Working position:	Any safe, Secure Position

Please Note: Specifications and improvements in the design of this unit and this manual are subject to change without any prior written notice.

Auto Sensing Voltage: This fixture contains an automatic voltage switch, which will auto sense the voltage when it is plugged into the power source.

Dear Customer,

The European Union has adopted a directive on the restriction / prohibition of the use of hazardous substances. This directive, referred to as ROHS, is a frequently discussed topic in the electronic industry.

It restricts, among other things, six materials: Lead (Pb), Mercury (Hg), hexavalent chromium (CR VI), cadmium (Cd), polybrominated biphenyls as flame retardant (PBB), polybrominated diphenyl, also a flame retardant (PBDE). The directive applies to nearly all electronic and electrical devices whose mode of operation involves electric or electromagnetic fields – in short: each kind of electronics we have around us in our households or at work.

As manufacturers of products of the brands of AMERICAN AUDIO, AMERICAN DJ, ELATION Professional and ACCLAIM Lighting, we are obligated to comply with the RoHS directive. Therefore, as early as two years prior to the directive coming into force, we started our search for alternative environmentally friendly materials and manufacturing processes.

Well before the RoHS directive took effect, all of our products were manufactured meeting the standards of the European Union. With regular audits and material tests we can still assure that the components we use are always RoHS-compliant and that the manufacturing process, as far as the state of technology allows, is environmentally friendly.

The ROHS directive is an important step to the protection of our environment. We, as manufactures, feel obligated to make our contribution in this respect.

Every year thousands of tonnes of electronic components, which are harmful to the environment, end up at the waste disposals around the world. To ensure the best possible disposal or recovery of electronic components, the European Union has adopted the WEEE directive.

The WEEE-system (Waste of Electrical and Electronic Equipment) can be compared with the system of the “Green Spot”, which has been in use for several years. The manufactures have to make their contribution to the utilization of waste at the time they release the product. Money resources obtained by doing so will be applied to develop a common system of waste management. Thereby we can ensure professional and environmentally friendly scraping and recycling program.

As manufactures, we are part of the German system of EAR and we make our contribution towards it.

(Registration in Germany: DE41027552)

That means that products of AMERICAN DJ and AMERICAN AUDIO can be left in the collection points free of charge and they will be used in the recycling program. Products of ELATION Professional, which are used only by professionals, shall be handled by us. Please send Elation products directly to us at the end of their lifetime so that we can professionally dispose of them.

Like the above ROHS, the WEEE directive is an important contribution to the environment protection and we are glad to help to clean the environment with this disposal system.

We are happy to answer any of your inquiries and welcome your suggestions at: info@americandj.eu

A.D.J. Supply Europe B.V.
Junostraat 2
6468 EW Kerkrade
The Netherlands
www.americandj.eu